



(Front View) GD87 (Rear View)

FEATURES

- Industry standard 8" (203mm) coaxial, 16 watt, loudspeaker with high quality factory installed 8 watt line matching transformer
Offers proven performance with wide frequency response
Post-mounted tweeter adds strength and a more attractive appearance
Ideal for multi-purpose commercial, industrial and institutional use
Individually packaged for stocking & ordering convenience

APPLICATIONS

Use Atlas Sound 8" (203mm) diameter, multi-purpose, coaxial loudspeaker Model GD87 for voice transmission, music and signal reproduction in high-quality commercial, industrial and institutional applications.

GENERAL DESCRIPTION

The speaker used in the GD87 is the next generation of Atlas high performance cone loudspeakers, very similar to the preceding C-Series speakers. The similarity in the sonic qualities ensures that contractors and designers who have worked with the Atlas Sound C803A Series in the past will know exactly what to expect when they use the GD87.

The high-quality, 25 watt Model GD87 utilizes a post mounted tweeter which adds strength to the assembly and provides an attractive appearance. This coaxial loudspeaker features a 45Hz-19kHz (nominal) frequency response and a broad, uniform dispersion pattern of 90° @ 2kHz. Such provisions allow for highly intelligible sound reproduction and better distribution for high-quality sound systems. The GD87 combines a full-size 8" (203mm) dia., low-frequency reproducer and a 3" (76mm) high-frequency reproducer. The two sections are coupled via a built-in crossover network. The woofer has a 10oz. (260g) ceramic magnet; the tweeter has a 2.35 oz. (67g) ceramic magnet. The unit has an average sensitivity of 96dB (1W/1M). The loudspeaker is matched with a high efficiency 8 watt 70.7V transformer with a maximum insertion loss of 0.6dB. This premium transformer is constructed of audio grade laminations and has a full range frequency response of +1dB from 50Hz to 15kHz. The primary taps are 1, 2, 4, and 8 watts.

ARCHITECT & ENGINEER SPECIFICATIONS

Unit shall be Atlas Sound 8" diameter. loudspeaker/transformer combination Model GD87. The low-frequency reproducer cone shall be a full 8" (203mm) in diameter and the high frequency reproducer cone shall be 3" (76mm) in diameter. The woofer shall have a 10oz. (260g) ceramic magnet; the tweeter shall have a 2.35oz. (67g) ceramic magnet. The two reproducer sections shall be coupled through a built-in crossover network. The crossover frequency shall be at 2800Hz. Frequency response range shall be 100Hz-10kHz (nominal). Average sensitivity shall be 97dB (1W/1M). Low frequency voice coil diameter shall be 1" (25mm) and operate in a magnet field of at least 10,600 gauss. Transformer primary voltage shall be 70.7V with a frequency response range of ±1dB-50Hz-15kHz and power taps at 1,2,4 & 8 watts. Insertion loss shall not exceed .6dB. The maximum depth of the loudspeaker/transformer package shall not exceed 2.875" (73mm).

GD87 SPECIFICATIONS table with columns for parameter and value. Includes sections for THIELE-SMALL PARAMETERS and Transformer Specifications.

Specifications subject to change without notice



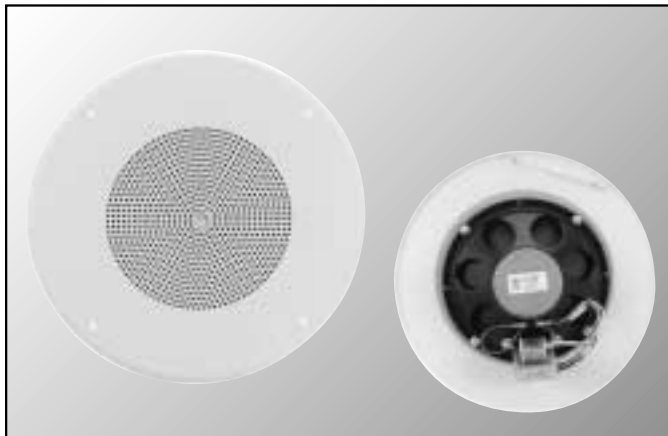

(Front View) GD87W (Rear View)

GD87W SPECIFICATIONS

Size	8" (205mm)
Power Handling	25 Watts Peak, 15 Watts RMS
Sensitivity	96dB Average
Impedance	8 Ohms Nomina
Frequency Response	45 Hz-19 kHz Nominal, 55 Hz-15 kHz ±5dB
Dispersion	105° (2 kHz Octave Band, -6dB Points)
Diameter & Depth	8.125" (205mm) Dia. & 2.875" (73mm) Deep
Mounting Dimensions	7.625" (194mm) Bolt Circle
Cone Material	Treated Paper
Surround Material & Damping	Damped Self Edge
Flux Density	10,600 Gauss, 1.06 Tesla
Magnet Weight	Nominal, 10 oz. (260g)
Basket Material	Stamped Plated 20 ga. CRS
VC Diameter	1" (25mm)
VC Material	Copper
VC Former Material	Black Anodized Aluminum
VC Winding Width	.225"
Top Plate Thickness	.239"
Weight	32 oz. (908g)
THIELE-SMALL PARAMETERS	
Pe	15 watts
Fs	125 Hz
Xmax	.05"
Resistance	7.3 ohms
Ots	0.8
Oes	0.95
Qms	5.2
BL	7.9 N/A
Efficiency	1.90%
Vas	.32 (ft3)
Sd	33.2 (in2)
Le@1kHz	.36 mH
Mms	.39 oz.
Cms	.024 in./lb.
Transformer Specifications	
Frequency Response	50Hz-15kHz (±1dB)
Primary Taps (Watts)	1, 2, 4 & 8
Secondary Impedance (ohms)	4 & 8
Maximum Insertion Loss	.6dB
Primary Termination	6" (152mm) Com. Lead Color Coded
Core Size	1" x 3/4" (25 X 19mm)
Power Rating (Watts)	8

FEATURES

- Industry standard 8" (203mm) coaxial, 16 watt, loudspeaker with high quality factory installed 8 watt line matching transformer and white CRS baffle
- Offers proven performance with wide frequency response
- Post-mounted tweeter adds strength and a more attractive appearance
- Ideal for multi-purpose commercial, industrial, and institutional use
- Individually packaged for stocking & ordering convenience

APPLICATIONS

Use Atlas Sound 8" (203mm) dia., multi-purpose, coaxial loudspeaker Model GD87W for voice transmission, music and signal reproduction in high-quality commercial, industrial and institutional applications.

GENERAL DESCRIPTION

The speaker used in the GD87W is the next generation of Atlas high performance cone loudspeakers, very similar to the preceding C-Series speakers. The similarity in the sonic qualities ensures that contractors and designers who have worked with the Atlas Sound C803A Series in the past will know exactly what to expect when they use the GD87W.

High-quality, 25 watt Model GD87W utilizes a post mounted tweeter which adds strength to the assembly and provides an attractive appearance. This coaxial loudspeaker features a 55Hz-15kHz ±5dB frequency response and a broad, uniform dispersion pattern of 90° @ 2kHz. Such provisions allow for highly intelligible sound reproduction and better distribution for high-quality sound systems. The GD87W combines a full-size 8" (203mm) dia. low-frequency reproducer and a 3" (76mm) high-frequency reproducer. The two sections are coupled via a built-in crossover network. The woofer has a 10oz. (260g) ceramic magnet; the tweeter has a 2.35oz. (67g) ceramic magnet. The unit has an average sensitivity of 96dB (1W/1M). The loudspeaker is matched with a high efficiency 8 watt 70.7V transformer with a maximum insertion loss of 0.6dB. This premium transformer is constructed of audio grade laminations and has a full range frequency response of +1dB from 50Hz-15KHz. The primary taps are 1, 2, 4, and 8 watts. The GD87W includes a factory installed CRS baffle with concealed loudspeaker mounting studs and includes screw mount hardware. The baffle finish is white powder coat epoxy.

ARCHITECT & ENGINEER SPECIFICATIONS

Unit shall be Atlas Sound 8" diameter, loudspeaker/transformer/baffle-combination Model GD87W The low-frequency reproducer cone shall be a full 8" (203mm) in diameter and the high frequency reproducer cone shall be 3" (76mm) in diameter. The woofer shall have a 10oz. (260g) ceramic magnet; the tweeter shall have a 2.35oz. (67g) ceramic magnet. The two reproducer sections shall be coupled through a built-in crossover network. The crossover frequency shall be at 2800Hz. Frequency response range shall be 55Hz-15kHz ±5dB. Average sensitivity shall be 96dB (1W/1M). Low frequency voice coil diameter shall be 1" (25mm) and operate in a magnet field of at least 10,600 gauss. Transformer primary voltage shall be 70.7V with a frequency response range of ±1dB-50Hz-15KHz and power taps at 1,2,4 & 8 watts. Insertion loss shall not exceed .6 dB. Unit shall include factory installed CRS baffle. Baffle shall include welded speaker mounting studs and all necessary hardware to match the baffle to associated optional hardware. Baffle overall diameter shall not exceed 12 1/4" (324mm) Baffle shall be finished in white powder coat epoxy. The maximum depth of the loudspeaker/transformer/baffle package shall not exceed 2.875" (73mm).

The GD87W baffle features standard mounting holes to accommodate the majority of Atlas Sound 8" tile bridges, mounting rings and enclosures. When specifying mounting hardware be advised that the dimensions of the GD87W baffle match the Atlas Sound Model 62-8.

Specifications subject to change without notice



Northeast Total Communications

Toll free: (800)-362-7542 Fax: (215)-639-2476 E-mail: info@ntcinc.com

GD87W Baffle Information							
MODEL	DIMENSIONS				MOUNTS		OPTIONAL TILEBRIDGE
	DIA. (A)	PROJECTS (B)	(C)*	(D)**	ENCLOSURE (OR)	MTG. RING	
GD87W	12 3/4" (324mm)	1/4" (6mm)	7 5/8" (194mm)	11 1/4" (286mm)	(EZ) 95-8 Series, T95-8 Series, EZ96-8, CS95-8(NS), 199-8, Q408, 96-8 Series [▲]	75-8(E1)(E2), 76-8(E1)(E2), P77-8, P78-8	81-8R(S) EQ81s [▲]

* (C) Speaker mounting stud pattern.

** (D) Baffle mounting hole pattern.

▲ EQ81 tile bridge works only with 96-8 Series enclosures.

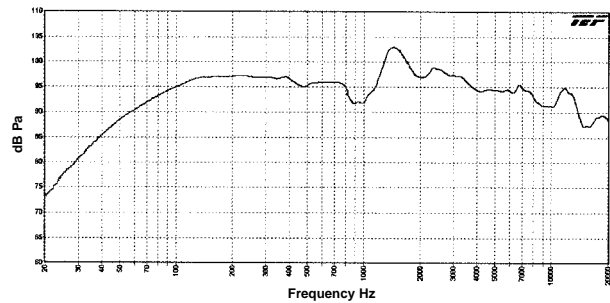
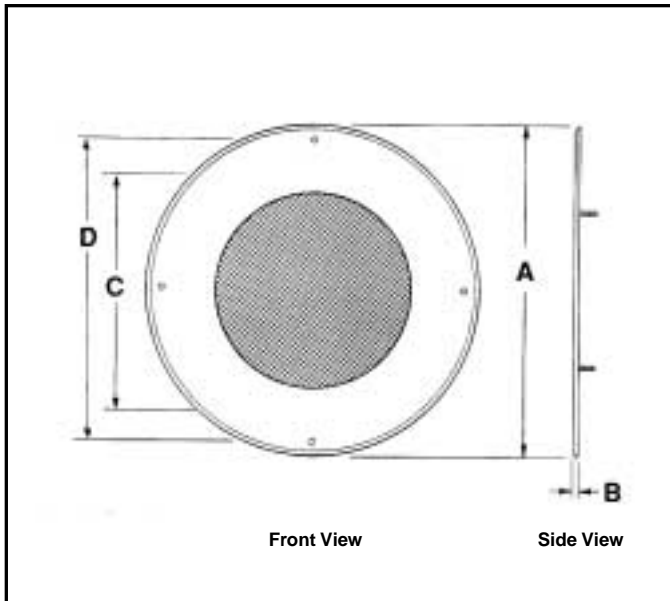

GD87W Frequency Response
(Transformer Bypassed)

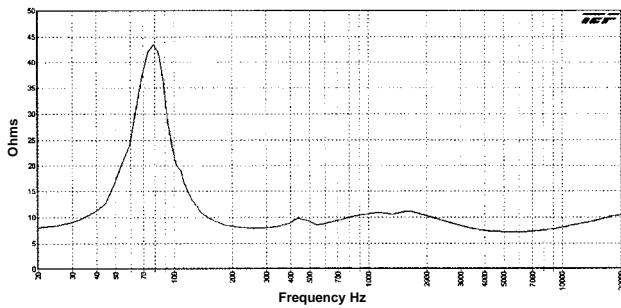

GD87W Impedance
(Transformer Bypassed)

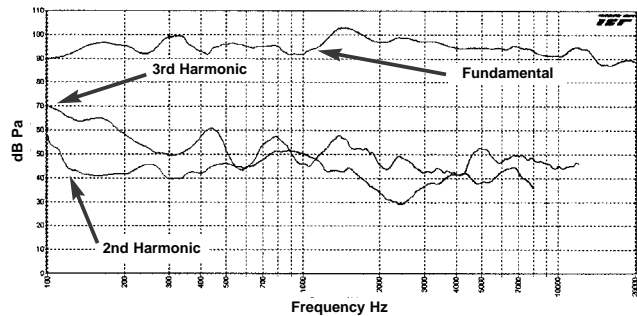

Fundamental vs. 2nd & 3rd Harmonics
(Transformer Bypassed)

GD87W OCTAVE BAND POLARS

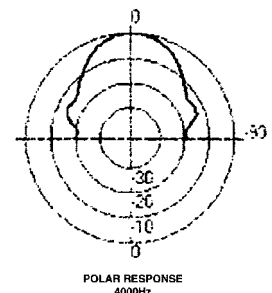
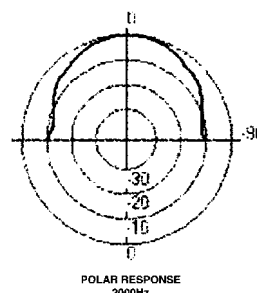
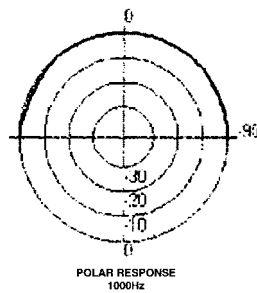
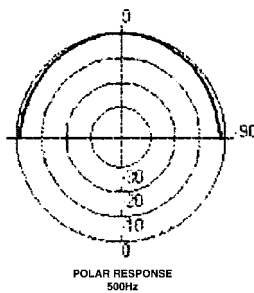

Specifications subject to change without notice



Northeast Total Communications

Toll free: (800)-362-7542 Fax: (215)-639-2476 E-mail: info@ntcinc.com

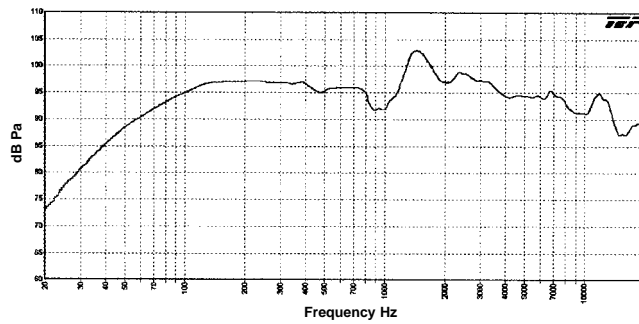

**GD87 Frequency Response
(Transformer Bypassed)**

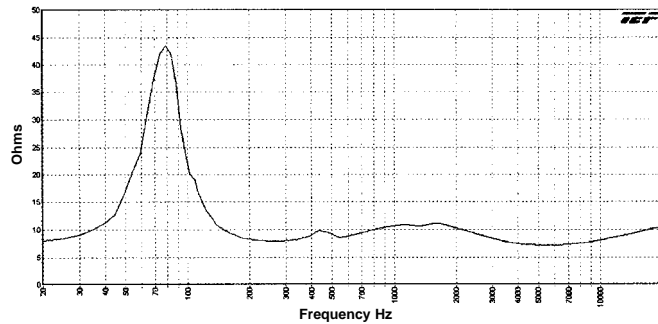

**GD87 Impedance
(Transformer Bypassed)**

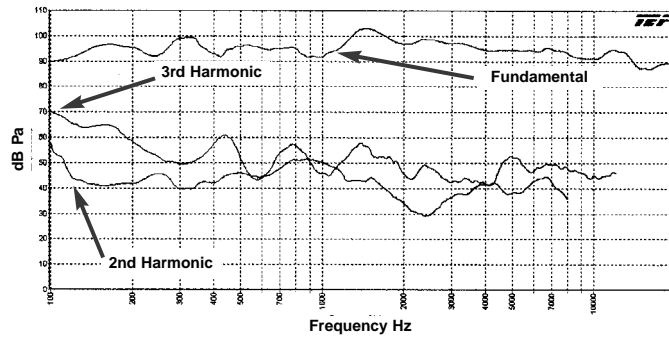

**Fundamental vs. 2nd & 3rd Harmonics
(Transformer Bypassed)**

GD87 OCTAVE BAND POLARS

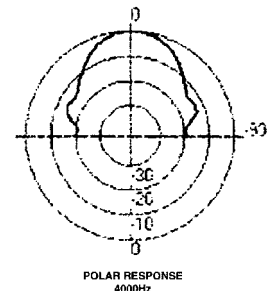
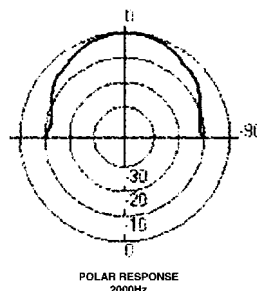
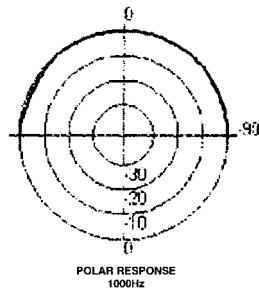
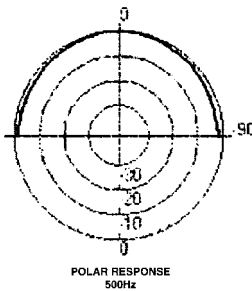

Specifications subject to change without notice



Northeast Total Communications

Toll free: (800)-362-7542 Fax: (215)-639-2476 E-mail: info@ntcinc.com