



ELECTRONIC SIREN LOUDSPEAKERS WITH WIDE-ANGLE DISPERSION

HPC-370GA



HPC-370GA

FEATURES

- 100-Watt Power Handling for High Intelligibility and Sound Penetration
- Engineered for Electronic Siren and Signalling Applications
- Heavy-Duty Weatherproof Construction
- Designed to Reduce Wind Resistance

APPLICATIONS

Utilize the HPC-370GA wide-angle loudspeaker for electronic siren, public address, and other high-intelligibility communication or signalling applications. Because of its heavy duty construction, they are suitable for mobile or stationary installations in land-based, marine, or airborne use. Model HPC-370GA (conservatively rated at 100 watts RMS in siren use and for public address voice functions) is recommended for high-powered systems in public safety, civil authority, military, or emergency medical applications. The HPC Series is offered in a choice of standard and custom configurations to meet varying mechanical and installation requirements.

GENERAL DESCRIPTION

Wide-angle siren loudspeaker HPC-370GA is rated at 100 watts. The double re-entrant, low profile styling reduces wind resistance and can be rack mounted to any ambulance, fire, law enforcement, utility, or other public service vehicle. The non-resonant, molded, Lexan® horn optimizes sound dispersion at any power level in a horizontal, exponential 70° x 115° pattern. The horn and heavy-gauge aluminum cover house the driver and provide complete weather and corrosion protection for all internal loudspeaker components. The HPC-370GA contains the patented Atlas Sound SD-370A Series compression driver (U.S. patent # 7,760,501) complete with a non-fatiguing, self-aligning sound-chamber assembly. Replacement driver assembly, Model SD-370A and Replacement head assembly Model K-370A are available for field replacement.

Model HPC-370GA siren loudspeaker is suitable for use with matched amplifiers and control equipment in systems requiring AMECA (Automotive Manufacturer Equipment Compliance Agency, Inc., formally the AAMVA) certification to General Services Administration specifications (KKK-A-1822C).

SEVEN

MODEL	POWER RATING	IMPEDANCE	FREQUENCY RESPONSE	SOUND Level (Peak)	DISPERSION **	DIMENSIONS W x H x D	EPOXY FINISH	SHIPPING WEIGHT
HPC-370GA	100 Watts* RMS	11 Ohms Nominal	375-8000 Hz Nominal (475-3000 Hz ±6dB)	111dBA*** 118dBA****	70°H x 115°V	4 7/8" x 6" 1 x 12 3/4" (365 x 152 x 324mm)	Grey/ Bell and Black Driver	13 lbs. (5.9 kg)

* 33 volts into 11 ohms = 100 watts ** 2000 Hz octave band, -6dB Points *** measured 1W/1M **** Measured at rated power, 3 meters

Specifications subject to change without notice



Northeast Total Communications

Toll free: (800)-362-7542 Fax: (215)-639-2476 E-mail: info@ntcinc.com

335



HPG-370GA

FEATURES

- Offers 100-Watt Power Handling with High Intelligibility and Sound Penetration
- Rugged, Compact, Weatherproof Construction
- Specifically Designed for Electronic Siren and Voice Communication Signaling on Emergency Vehicles

APPLICATIONS

Utilize heavy-duty siren loudspeaker Model HPG-370GA for high-powered transmission of electronic siren and voice communications in vehicular applications. Because of the unit's ruggedness and compact size, it is suitable for installation within standard-sized lightbars, engine compartments, or for mounting in front of the radiator or on the bumper of any ambulance, fire, law enforcement, utility, or other public service vehicle.

GENERAL DESCRIPTION

Atlas Sound siren loudspeaker Model HPG-370GA is a reflex-type loudspeaker with a rectangular molded bell. It is rated at 100 watts RMS in electronic siren use.

Model HPG-370GA provides optimum sound level output of 120dB (measured at 1600 Hz, rated power, 3 meters on axis) and features a directed dispersion range of 120H° x 140V° (1 kHz octave band) to assure high-intensity acoustic penetration for electronic siren signals.

Unit contains the patented Atlas Sound SD-370A compression driver (U.S. Patent #7,760,501) complete with a non-fatiguing, self-aligning sound chamber assembly. These drivers have earned acceptance as the quality and performance standard for 100-watt electronic signal systems in police, fire, ambulance, and utility vehicles throughout the world.

A patented, heavy-duty, one piece steel mounting bracket (U.S. patent #394,660) permits full-axis orientation of the loudspeaker for preferred sound-projection directivity. The projector assembly is manufactured of plastic and finished in black. The driver is finished in black baked epoxy for optimum durability and corrosion protection. Units are shipped complete with all components and installation data for field installation. Replacement head assembly (Model K-370A) or driver assembly (Model SD-370A) are available for field replacement.

Product series is suitable for use with matched amplifier and control equipment in systems requiring AMECA (Automotive Manufacturer Equipment Compliance Agency, Inc., formerly the AAMVA) certification to General Services Administration specifications (KKK-A-1822C).

SEVEN

Specifications subject to change without notice



SPECIFICATIONS								
MODEL	POWER RATING	IMPEDANCE	FREQUENCY RESPONSE	SOUND LEVEL **	DISPERSION *****	DIMENSIONS W x H x D	FINISH	SHIPPING WEIGHT
HPG-370GA	100 Watts RMS	11 Ohms Nominal	450 - 3800 Hz (± 10dB) Nominal	110dB*** 116dB****	80° x 105° (1 kHz Octave Band)	7 ⁷ / ₁₆ " x 5 ³ / ₈ " x 7" (186 x 137 x 178mm)	Black Driver and Bell	6.5 lbs (2.9 kg)

*HPF = High Pass Filtered **Peak (dBA) ***Measured at 1600 Hz rated power, 3 meters on axis. (Ref.: .0002 dynes/cm²)
 ****Measured at 1 watt, 1 meter. (Ref.: .0002 dynes/cm²) *****2000 Hz octave band, -6dB points

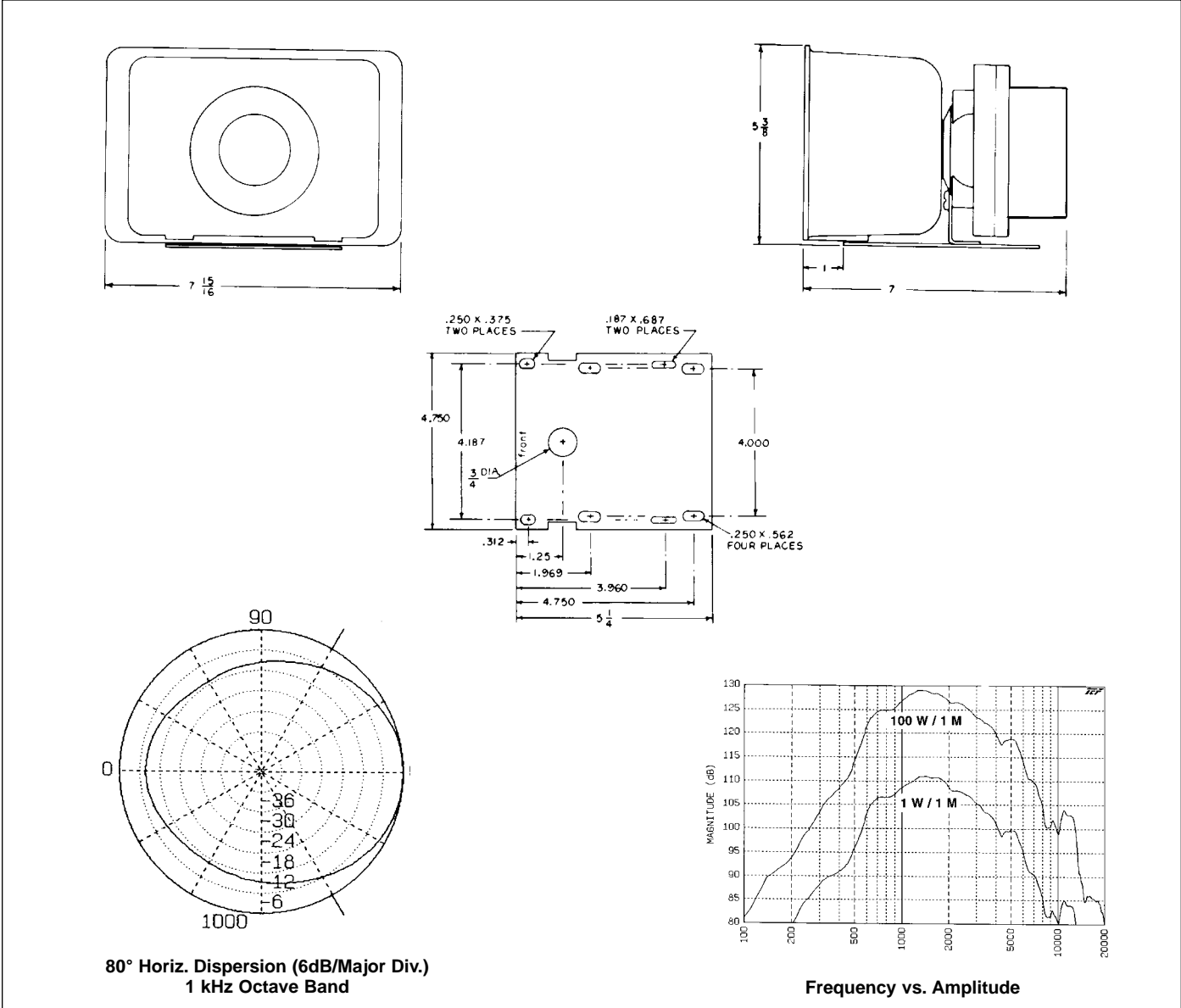

80° Horiz. Dispersion (6dB/Major Div.)
1 kHz Octave Band

Frequency vs. Amplitude

ARCHITECT & ENGINEER SPECIFICATIONS

Siren loudspeaker shall be Atlas Sound Model HPG-370GA. Assembly shall be of the reflex type and include an 11-ohm compression driver. Power rating shall be 100 watts RMS with nominal frequency response range of 450-3800 Hz (±10dB). Dispersion angle shall be 80° x 105° in the 1 kHz octave band. Sound level shall be 116dB

when measured at 1600 Hz rated power at 3 meters (ref: .0002 dynes/cm²). Unit shall be furnished with a steel mounting bracket and have a field-replaceable driver-head assembly. Termination shall be complete via 20" (508 mm) 18-gauge, color-coded leads.

Specifications subject to change without notice



Northeast Total Communications

Toll free: (800)-362-7542 Fax: (215)-639-2476 E-mail: info@ntcinc.com